

# $\alpha$ -Halo Sulfones. VI. Evidence for the Intermediacy of Thiirene Dioxides in the Base-Promoted Rearrangement of $\alpha,\alpha$ -Dichloro Sulfones<sup>1-3</sup>

Leo A. Paquette<sup>4</sup> and Lawrence S. Wittenbrook

Contribution from the Department of Chemistry, The Ohio State University, Columbus, Ohio 43210. Received March 19, 1967

**Abstract:** The rearrangement of  $\alpha,\alpha$ -dichlorodibenzyl sulfones in base is shown to proceed *via* initial formation of chloro episulfone intermediates produced in a 1,3 elimination of hydrogen chloride. The major portion of such intermediates is seen to undergo further base-promoted loss of hydrogen chloride to afford thiirene dioxides which are attacked by hydroxide ion to yield vinylsulfonic acids or which experience decomposition to diphenylacetylenes.

Since the discovery<sup>5</sup> that acyclic sulfones possessing an  $\alpha$ -halogen substituent and at least one  $\alpha'$ -hydrogen atom can be readily transformed into alkenes upon treatment with dilute alkali, such rearrangements have commanded considerable attention at the mechanistic level. These interesting transformations which follow second-order kinetics (first order in base and first order in sulfone) are believed to proceed by means of an initial rapid preequilibrium between the sulfone and its anion,<sup>6</sup> followed by a rate-determining 1,3-displacement of halide ion and rapid expulsion of sulfur dioxide from the resulting intermediate episulfone.<sup>3d,e,8,9</sup> Although certain aspects of the over-all process such as the apparent preference for *cis* stereochemistry in the episulfone-forming step and the precise nature of the mechanism by which the sulfur dioxide is lost remain to be clarified, this reaction is endowed with considerable synthetic promise.<sup>3b,10</sup>

To a degree, therefore, the Ramberg-Bäcklund rearrangement parallels in a mechanistic sense the Favor'skii reaction of  $\alpha$ -halo ketones which has been shown to proceed, at least in certain instances, *via* an intermediate possessing the symmetry of a cyclopropanone.<sup>11,12</sup> Because such intermediate cyclopropanones can often be intercepted as stable cyclopropanones when dihalo ketones are employed as starting

materials,<sup>13,14</sup> we were led to an investigation of the base-induced rearrangements of  $\alpha,\alpha$ -dichloro sulfones in the expectancy that an initial 1,3 displacement of chloride ion would similarly be followed by a 1,2 elimination of hydrogen chloride and eventuate in the formation of thiirene 1,1-dioxides (**1**). Should such

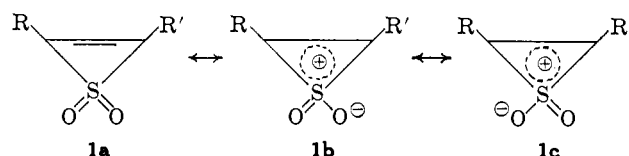

unsaturated heterocycles receive ground-state stabilization of the type implied by possible hybrid contributors **1b** and **1c** (a comparable delocalized structure is known to exist in cyclopropanones<sup>13,15</sup>), the isolation of such molecules from the alkaline reaction mixture would perhaps be possible. Such a result would obviate a criticism which may be leveled at the mechanism of the Ramberg-Bäcklund rearrangement, namely that in no case has an intermediate episulfone been isolated under the reaction conditions. On the other hand, the well-established instability of episulfones to base and heat is consonant with their nonisolatability under the usual reaction conditions.<sup>3,9,16</sup>

## Results

$\alpha,\alpha$ -Dichlorodibenzyl sulfones were chosen for the present study.<sup>17</sup> Initially, the rearrangement of  $\alpha,\alpha$ -

(1) This investigation was supported in part by the Petroleum Research Fund, administered by the American Chemical Society, to whom the authors express their appreciation.

(2) Presented in part at the 151st National Meeting of the American Chemical Society, Pittsburgh, Pa., March 1966.

(3) For the previous papers in this series, refer to (a) V: L. A. Paquette and L. S. Wittenbrook, *Chem. Commun.*, 471 (1966); (b) IV: L. A. Paquette, *J. Am. Chem. Soc.*, **86**, 4383 (1964); (c) III: L. A. Paquette, *J. Org. Chem.*, **29**, 2854 (1964); (d) II: L. A. Paquette, *J. Am. Chem. Soc.*, **86**, 4089 (1964); (e) I: L. A. Paquette, *ibid.*, **86**, 4085 (1964).

(4) Fellow of the Alfred P. Sloan Foundation.

(5) L. Ramberg and B. Bäcklund, *Arkiv Kemi, Mineral. Geol.*, **13A**, No. 27 (1940); *Chem. Abstr.*, **34**, 4725 (1940).

(6) Deuterium exchange studies have conclusively proven that  $\alpha$ -sulfonyl carbanions are rapidly generated under the reaction conditions. However, these data do not necessarily require that such carbanions occur on the reaction pathway leading to olefins.<sup>7</sup> In other words, the available evidence cannot distinguish between concerted proton abstraction and discrete carbanion formation in the product-forming transition state.

(7) R. Breslow, *Tetrahedron Letters*, 399 (1964).

(8) F. G. Bordwell and G. D. Cooper, *J. Am. Chem. Soc.*, **73**, 5187 (1951).

(9) (a) N. P. Neureiter and F. G. Bordwell, *ibid.*, **85**, 1209 (1963); (b) N. P. Neureiter, *ibid.*, **88**, 558 (1966).

(10) N. P. Neureiter, *J. Org. Chem.*, **30**, 1313 (1965).

(11) A. S. Kende, *Org. Reactions*, **11**, 261 (1960).

(12) D. J. Cram, "Fundamentals of Carbanion Chemistry," Academic Press Inc., New York, N. Y., 1965, pp 243-249.

(13) (a) R. Breslow, L. J. Altman, A. Krebs, E. Mohacs, I. Murata, R. A. Peterson, and J. Posner, *J. Am. Chem. Soc.*, **87**, 1326 (1965); (b) R. Breslow, T. Eicher, A. Krebs, R. A. Peterson, and J. Posner, *ibid.*, **87**, 1320 (1965); (c) R. Breslow, J. Posner, and A. Krebs, *ibid.*, **85**, 234 (1963), and pertinent references cited in the above papers.

(14) N. J. McCorkindale, R. A. Raphael, W. T. Scott, and B. Zwanenburgh, *Chem., Commun.*, 133 (1966).

(15) R. Breslow and L. J. Altman, *J. Am. Chem. Soc.*, **88**, 504 (1966).

(16) L. A. Paquette and L. S. Wittenbrook, *J. Org. Chem.*, **31**, 1997 (1966), and references cited therein.

(17) Although preliminary considerations suggested that an investigation of the reactivity of  $\alpha,\alpha$ - or  $\alpha,\alpha'$ -dibromo sulfones with base would perhaps be most rewarding because of the well-established ease of displacement of bromide ion (at least relative to chloride ion; this would permit the use of milder conditions), our attention was directed away from such substrates after close scrutiny of Scholnick's results.<sup>18</sup> Thus, this researcher discovered that, despite the use of pure  $\alpha,\alpha$ -dibromo sulfones as starting materials, considerable quantities of olefins derived apparently from  $\alpha$ -bromo sulfones were obtained; such observations were later attributed to the fact that sulfite ion, liberated in the earlier stages of the rearrangement (from the reaction of the evolved sulfur dioxide with hydroxide ion), effectively reduced the  $\alpha,\alpha$ -dibromo sulfones to their monobromo counterparts. In order to avoid this complication which would have rendered a quantitative appraisal of the expected

Table I.  $\alpha,\alpha$ -Dichlorodibenzyl Sulfone (2) Rearrangements

Base	Molar equiv, base	Solvent	Temp, °C	Product, %			
				3	4	5	6
2.0 N NaOH	6	H <sub>2</sub> O-dioxane (1:1)	87	23	2	2	70
1.0 N NaOH	6	H <sub>2</sub> O-dioxane (1:1)	87	22	2	3	74
1.0 N NaOH	3	H <sub>2</sub> O-dioxane (1:1)	87	5 <sup>a</sup>	<1	<1	65
0.5 N NaOH	3	H <sub>2</sub> O-dioxane (1:1)	87	7 <sup>a</sup>	<1	<1	58
2.0 N KOH	6	H <sub>2</sub> O	100	10	6	5	66
1.06 M KO- <i>t</i> -Bu	6	<i>t</i> -BuOH	84	37	2	3.5	0

<sup>a</sup> The lower yields in these cases are due to the fact that discrete amounts of 2 remained at the end of the reaction period.

dichlorodibenzyl sulfone (2) in a variety of bases and solvents was examined (Table I). The clear preference for the formation of vinylsulfonic acid 6 (Chart I) in the presence of hydroxide ion was found to drop off sub-

Chart I

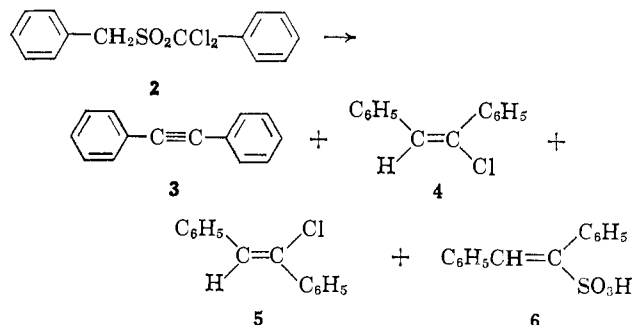

stantially when the strong hindered base, potassium *t*-butoxide, was employed. In fact, no quantity of 6 could be detected in the reaction mixture. Thus, the nature of the base exerts a profound influence upon the product composition at some stage of the rearrangement process. In contrast, medium changes appear to have only minor effect when hydroxide ion is present.

Evidence that the diphenylacetylene (3) did not find its origin in the dehydrohalogenation of 4 or 5, especially when hydroxide ion was utilized, was derived from the appropriate control experiments on independently prepared chloro olefins (see Table II).<sup>19</sup> Furthermore, sulfite ion liberated during the course of the rearrangement was demonstrated not to interact with 3, 4, or 5 under the reaction conditions employed, and therefore these products are likewise not precursors of 6.

Table II. Control Experiments

Chloro-olefin	Base	Solvent, conditions	Results
4	2.0 N NaOH	H <sub>2</sub> O-dioxane (1:1), reflux, 4 hr	Recovered intact; no 3 detected
4	1.06 M KO- <i>t</i> -Bu	<i>t</i> -BuOH, reflux, 0.5 hr	Complete conversion to 3
5	2.0 N NaOH	H <sub>2</sub> O-dioxane (1:1), reflux, 4 hr	Recovered intact; no 3 detected
5	1.06 M KO- <i>t</i> -Bu	<i>t</i> -BuOH, reflux, 0.5 hr	Complete conversion to 3

results very difficult,  $\alpha,\alpha$ -dichloro sulfones were utilized herein. Sulfite reduction was not experienced in our earlier work with such molecules.<sup>3d</sup> (18) F. Scholnick, Ph.D. Dissertation, University of Pennsylvania, 1955.

(19) The authors wish to thank Professor Stanley J. Cristol for making pure samples of 4 and 5 available to them.

The rearrangement reaction was extended to include sulfones 10 and 13. The synthetic approaches to these substances are outlined in Chart II. Condensation

Chart II

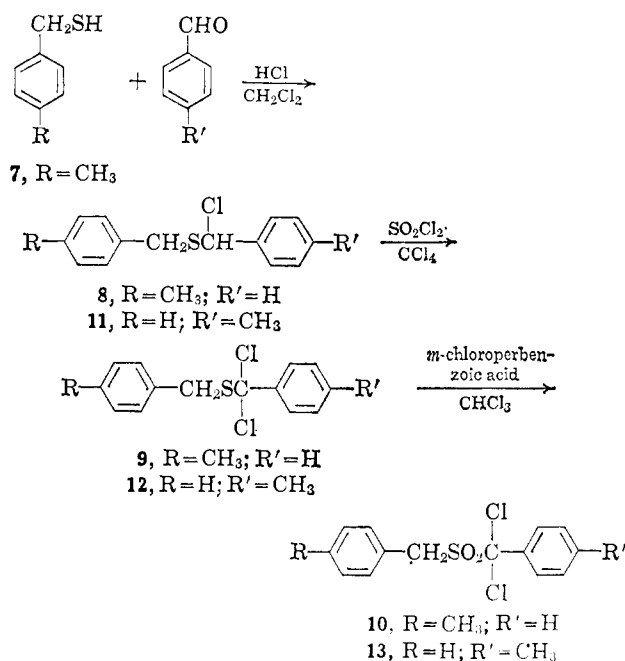

of *p*-methylbenzyl mercaptan (7) with benzaldehyde in the presence of anhydrous hydrogen chloride yielded the  $\alpha$ -chloro sulfide 8.<sup>20</sup> Chlorination of 8 with 1 equiv of sulfuryl chloride, followed by oxidation of the resulting  $\alpha,\alpha$ -dichloro sulfide 9 with *m*-chloroperbenzoic acid, led to the isolation of the desired 10. A similar reaction sequence with benzyl mercaptan and *p*-tolualdehyde gave rise to the isomeric  $\alpha,\alpha$ -dichloro sulfone 13.

When either 10 or 13 was subjected to the action of 2.0 N sodium hydroxide in aqueous dioxane, there resulted an identical mixture of products except, of course, in the nature of the vinyl chlorides (Chart III). In both cases, the neutral products were assayed by vapor phase chromatography, and the vinylsulfonic acids 14 and 15 were isolated as a mixture of *p*-toluidine salts. The infrared and nmr spectra of the sulfonic acid salt mixtures from both sources were superimposable; excellent melting point correspondence was also observed. Furthermore, in the nmr spectra, the singlet

(20) The condensation of aldehydes with mercaptans in the presence of hydrogen chloride as a preparative route to  $\alpha$ -chloro sulfides has been employed previously: see ref 3b and (a) H. Bohme, *Ber.*, **69**, 1612 (1936); (b) H. Bohme, H. Fischer, and R. Frank, *Ann.*, **563**, 54 (1949); (c) L. A. Walter, L. H. Goodson, and R. J. Fosbinder, *J. Am. Chem. Soc.*, **67**, 655, 657 (1945); (d) H. Bohme, L. Tils, and B. Unterhalt, *Chem. Ber.*, **97**, 179 (1964).

Chart III

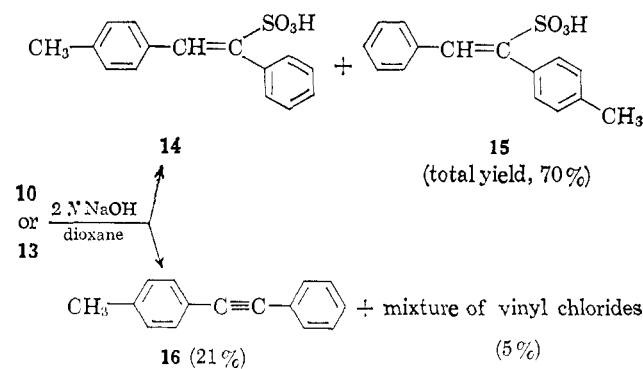

attributable to the *p*-toluidine methyl group ( $\delta$  2.28)<sup>21</sup> comprised an area equal to the combined intensities displayed by the aryl methyl groups of **14** and **15** (singlets at  $\delta$  2.15 and 2.37); most enlightening, however, was the observation that the latter absorption peaks were of equal intensity. This ratio of peak areas uniquely corresponds to an equimolar mixture of **14** and **15** in the two examples.

### Discussion

On the basis of the above data, the base-promoted rearrangements of these  $\alpha,\alpha'$ -dichloro sulfones can be interpreted uniquely in terms of an initial 1,3 elimination of hydrogen chloride to provide chloro episulfone intermediates such as **17** which may either undergo loss of sulfur dioxide and eventuate in vinyl chloride production or base-induced loss of an additional molecule of hydrogen chloride. In the latter event, thiirene dioxides

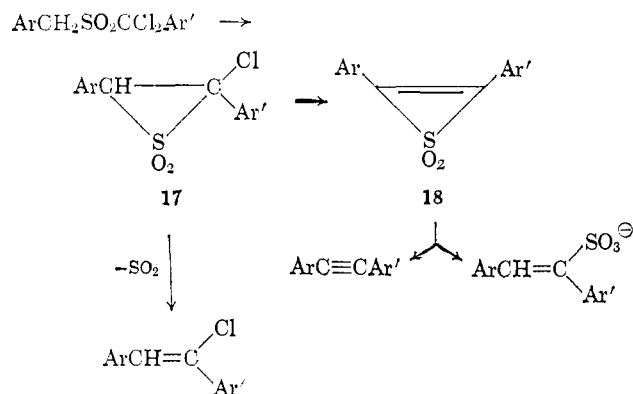

such as **18** result; these strained heterocycles are then subject either to loss of sulfur dioxide<sup>22</sup> or to conversion to sulfonic acids.

The identity of the sulfonic acid composition from the rearrangement of **10** and **13** demands that a common precursor to these end products be formed at some stage of the rearrangement process. This entity can only be the thiirene dioxide **19**. Therefore, conclusive evidence for the intermediacy of such unsaturated cyclic sulfones is at hand, and alternative mechanisms for sulfonic acid formation such as concerted attack at the tetravalent sulfur atom of chloro episulfones and ejection of chloride ion (*viz.*, **20** and **21**)<sup>3d</sup> or sequences

(21) The nmr spectra were recorded in DMSO-*d*<sub>6</sub> solution.

(22) A discussion of the fact that acetylene formation can only be reconciled with thiirene dioxide formation is delayed to the accompanying paper: L. A. Paquette, L. S. Wittenbrook, and V. V. Kane, *J. Am. Chem. Soc.*, **89**, 4487 (1967).

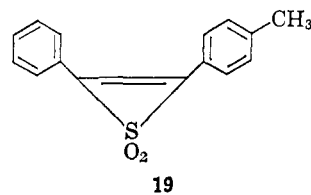

of the type depicted in equations A and B are effectively removed from consideration.

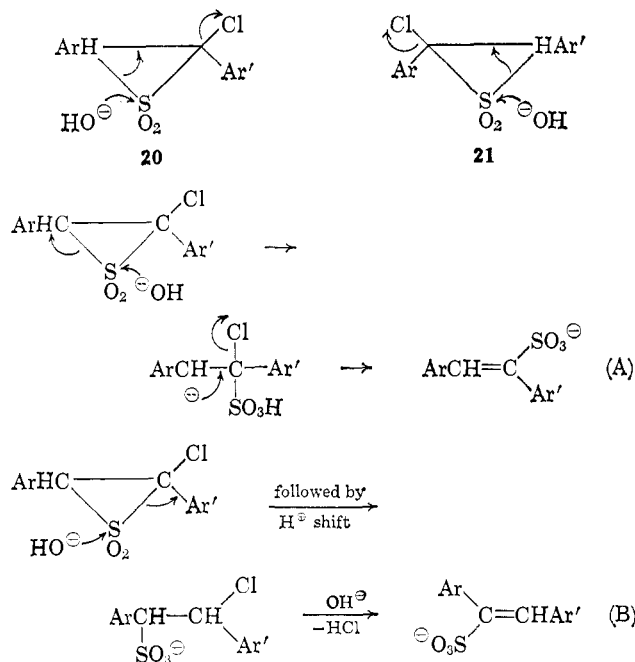

Unfortunately, it has not proven possible to isolate thiirene dioxides from the above rearrangements. However, Carpino and McAdams<sup>23</sup> have recently shown that  $\alpha,\alpha'$ -dibromodibenzyl sulfone (**22**) can be converted to the stable crystalline 2,3-diphenylthiirene 1,1-dioxide (**23**) in 70% yield by treatment with triethylamine in methylene chloride solution. Interest-

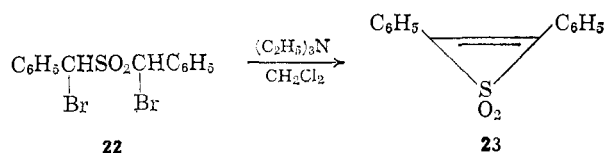

ingly,  $\alpha,\alpha'$ -dichloro sulfones **2**, **10**, and **13** are totally unaffected by this reagent and actually react only very slowly with aqueous hydroxide solution in the 0–40° temperature range.

The isolation of **23** from this modified Ramberg-Bäcklund rearrangement, and the chemical reactivity of this heterocycle,<sup>23,24</sup> serve to confirm further the intermediacy of thiirene dioxides.

The formation of the isomeric vinyl chlorides **4** and **5** deserves some comment. Given the hypothesis that chloro episulfones such as **17** decompose stereospecifically to chloroolefins in a manner paralleling the behavior of dialkyl episulfones,<sup>9,25</sup> then the stereochemistry of these halides is determined in the cyclization step. The two possible transition states thus impli-

(23) L. A. Carpino and L. V. McAdams, III, *ibid.*, **87**, 5804 (1965).

(24) L. A. Carpino and R. H. Rynbrandt, *ibid.*, **88**, 5682 (1966).

(25) This aspect of the Ramberg-Bäcklund rearrangement is presently under investigation in this laboratory.

cated in the ring-forming process are **25** and **27**.<sup>26</sup> However, the data of Table I cannot be utilized to

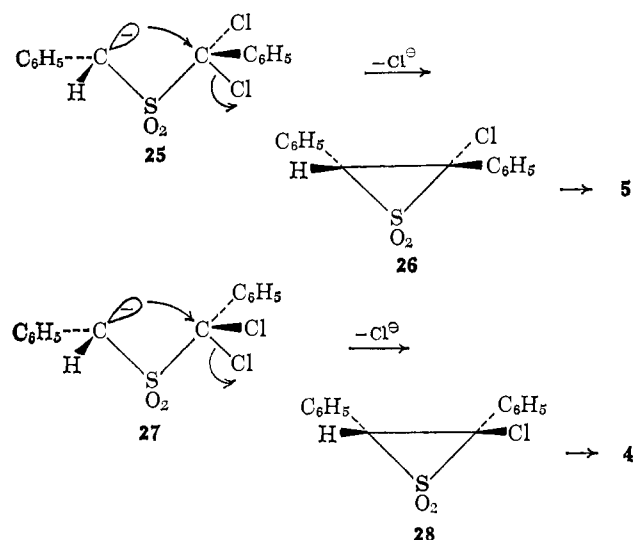

evaluate the relative amounts in which **25** and **27** are produced because different relative rates of elimination of hydrogen chloride from **26** and **28** can be expected (due to the *trans* and *cis* nature, respectively, of the groups to be eliminated) and stereochemical meaning is lost upon thiirene dioxide production. It is interesting, and undoubtedly relevant, to compare these results with the known<sup>8</sup> transformation of  $\alpha$ -chlorobenzyl benzyl sulfone exclusively to *trans*-stilbene under comparable conditions.

Finally, we wish to call attention to the fact that sulfur dioxide expulsion from thiirene dioxides may be considered yet another example of an electrocyclic process<sup>27</sup> occurring in a three-membered ring. It is now commonly recognized<sup>28</sup> that the stereospecific decomposition of episulfones constitutes an exception to the present theory. By means of similar argumentation, it can be shown that concerted conrotatory decomposition of thiirene dioxides to acetylenes is likewise symmetry forbidden (eq C). It is not known whether,

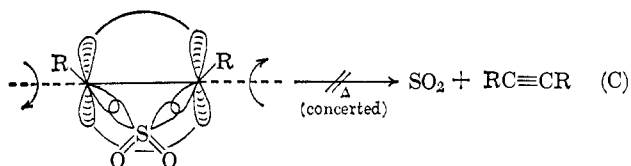

in the formation of acetylenes, a strong nucleophile can participate in the apparently nonconcerted bond cleavage process. Hydroxide ion attack at tetravalent sulfur is obviously required in the conversion into sulfonic acids, although the exact moment of S-O bond formation (*i.e.*, prior to, or after, ring rupture) remains unknown. The absence of sulfonic acids when potassium *t*-butoxide is utilized as base<sup>29</sup> suggests that this hindered base is incapable of bonding to sulfur,<sup>30</sup>

(26) Discrete carbanionic entities are employed here only to achieve simplicity of illustration; the structures are not meant to imply that a concerted 1,3 elimination has been removed from consideration by us.

(27) (a) R. B. Woodward and R. Hoffmann, *J. Am. Chem. Soc.*, **87**, 395 (1965); (b) R. Hoffmann and R. B. Woodward, *ibid.*, **87**, 2046 (1965); (c) we wish to acknowledge a helpful discussion with Professor R. Hoffmann with regard to this problem.

(28) See, for example, J. P. Freeman and W. H. Graham, *ibid.*, **89**, 1767 (1967).

(29) This phenomenon is apparently general; see subsequent paper.<sup>22</sup>

it has not yet been established whether this effect is attributable to steric factors or to some as yet unrecognized phenomenon.

### Experimental Section<sup>31</sup>

$\alpha,\alpha$ -Dichlorodibenzyl Sulfone (**2**). This sulfone was prepared by the method of Paquette,<sup>3d</sup> mp 134–135° (lit.<sup>3b</sup> mp 134–135°).

**Typical Procedure for the Rearrangement of 2 in Hydroxide Solutions.** To a stirred solution of 3.15 g (10 mmoles) of **2** in 30 ml of purified dioxane was added in one portion 30 ml of 2.0 *N* sodium hydroxide solution (60 mmoles). After a reflux period of 4 hr, the reaction mixture was cooled and water (50 ml) was added, and the solution was extracted with three 50-ml portions of methylene chloride. The combined organic layers were washed with water, dried, filtered, and evaporated *in vacuo* at room temperature to a volume of approximately 50 ml. Careful fractionation of this solution gave two cuts boiling at 42–60 and 60–99° (major portion) which were composed solely (by vpc) of methylene chloride-dioxane mixtures. Vpc analysis of the residue (1.12 g) on a 10 ft  $\times$  0.25 in. aluminum column packed with 2% XF1150 on Chromosorb P provided the following product distribution:<sup>32</sup> 1-chloro-*cis*-1,2-diphenylethylene (**4**), 2%;<sup>19</sup> diphenylacetylene (**3**), 23%;<sup>33</sup> and 1-chloro-*trans*-1,2-diphenylethylene (**5**), 2%.<sup>19</sup>

The aqueous layer from the reaction mixture was acidified with concentrated hydrochloric acid to pH 3, and to this solution was added 1.5 g (15.0 mmoles) of *p*-toluidine. The volume of the solution was reduced *in vacuo* to about 50 ml. Upon cooling, a pale yellow solid was obtained; further concentration of the filtrate gave a total of 2.04 g (70.3%) of this solid. Recrystallization of the material so obtained from water gave pure *p*-toluidine salt of **6**, mp 198° dec (lit.<sup>3d</sup> mp 198° dec).

**Rearrangement of 2 with Potassium *t*-Butoxide in *t*-Butyl Alcohol.** A 4.73-g (15 mmoles) sample of **2** was placed in the reaction flask, and the system was blanketed with nitrogen. There was added in one portion through a syringe 85 ml of a 1.06 *M* potassium *t*-butoxide solution in *t*-butyl alcohol (90 mmoles). The resulting solution was refluxed with stirring for 0.5 hr. The reaction mixture was cooled, 50 ml of water was added, and the remainder of the work-up proceeded as above. The results are summarized in Table I.

$\alpha,\alpha$ -Dichloro-4-methylbenzyl Benzyl Sulfone (**13**). A solution of 19.2 g (0.16 mole) of *p*-tolualdehyde in 60 ml of dichloromethane was added dropwise to a vigorously stirred solution of 18.6 g (0.15 mole) of benzyl mercaptan in 200 ml of dichloromethane at  $-15^\circ$  while introducing gaseous hydrogen chloride below the surface of the reaction mixture. The addition required 2 hr, and the hydrogen chloride was introduced for an additional 0.5 hr. An excess of granular, anhydrous calcium chloride was added carefully to the reaction mixture ( $-15^\circ$ ) to remove the water formed during the reaction. Removal of excess hydrogen chloride was accomplished *in vacuo* at  $-10^\circ$ . The calcium chloride was filtered and washed with dichloromethane. Evaporation of the filtrate *in vacuo* gave crude  $\alpha$ -chloro-4-methylbenzyl benzyl sulfide (**11**) as a pink oil. To a solution of this crude sulfide in 160 ml of carbon tetrachloride was added at 35–40° 27.0 g (0.20 mole) of sulfur tetrachloride over a 0.5-hr period. Following this addition, the yellow solution was refluxed for 1 hr. After cooling, the solvent was removed *in vacuo*, and the crude **12** was not further purified but was taken up in 50 ml of cold chloroform. The resulting solution

(30) The *t*-butyl sulfonate esters which would be produced if this process were occurring would not be expected to survive the reaction conditions because of their known ease of solvolysis to isobutylene and sulfonic acid salts [see, for example, H. M. Hoffmann, *Chem. Ind. (London)*, 336 (1963); J. F. King and T. Durst, *J. Am. Chem. Soc.*, **87**, 5684 (1965)].

(31) Melting points were determined with a Thomas-Hoover capillary melting point apparatus and are uncorrected. Infrared spectra were recorded with a Perkin-Elmer Infracord Model 137 spectrometer fitted with sodium chloride prisms. Nuclear magnetic resonance spectra were obtained with a Varian A-60 spectrometer purchased with funds made available through the National Science Foundation. The microanalyses were performed by the Scandinavian Microanalytical Laboratory, Herlev, Denmark. The vpc analyses were obtained with an Aerograph A-90P gas chromatograph (helium as the carrier gas); percentage compositions refer to the calibrated relative areas observed for the different components.

(32) Residual dioxane excluded; percentages refer to over-all yield from the dichloro sulfone.

(33) Identical in all respects with a commercial sample.

was added dropwise to a stirred slurry of 82 g (0.38 mole) of *m*-chloroperbenzoic acid (80% active ingredient) in 380 ml of chloroform previously cooled to 0° in an ice bath. The rate of addition was controlled to maintain the reaction temperature at 0°. When the addition was completed, the reaction mixture was allowed to stand overnight at room temperature. The insoluble *m*-chlorobenzoic acid was removed by filtration and was washed with a small amount of cold chloroform. The combined filtrates were washed three times with saturated sodium bicarbonate solution, three times with water, dried over magnesium sulfate, and evaporated. Recrystallization of the crude oxidation product from hexane-benzene gave 6.0 (13%) of **13**, mp 120–135°. Three recrystallizations from cyclohexane afforded pure white crystals, mp 144–145°;  $\nu_{\text{max}}^{\text{Nujol}}$  7.51 and 8.77  $\mu$  (SO<sub>2</sub>);  $\tau_{\text{TMS}}^{\text{CDCl}_3}$  7.65 (singlet, 3 H, CH<sub>3</sub>Ar), 5.39 (singlet, 2 H, PhCH<sub>2</sub>SO<sub>2</sub>), and 2.1–2.9 (multiplet, 9 H, aromatic protons).

*Anal.* Calcd for C<sub>15</sub>H<sub>14</sub>Cl<sub>2</sub>O<sub>2</sub>S: C, 54.72; H, 4.29; Cl, 21.54. Found: C, 54.77; H, 4.36; Cl, 21.37.

**$\alpha,\alpha$ -Dichlorobenzyl 4-Methylbenzyl Sulfone (10).** In a procedure identical with that described above, 17.0 g (0.16 mole) of benzaldehyde was condensed with 20.7 g (0.15 mole) of 4-methylbenzyl mercaptan.<sup>34</sup> The crude  $\alpha$ -chloro sulfide was chlorinated and oxidized, and the crude  $\alpha,\alpha$ -dichloro sulfone was recrystallized from benzene-hexane. There was obtained 13.5 g (27%) of white solid, mp 137–140°. Several recrystallizations from cyclohexane gave pure **10** as white needles, mp 148–149°;  $\nu_{\text{max}}^{\text{Nujol}}$  7.52 and 8.73  $\mu$  (SO<sub>2</sub>);  $\tau_{\text{TMS}}^{\text{CDCl}_3}$  7.66 (singlet, 3 H, CH<sub>3</sub>Ar), 5.39 (singlet, 2 H, Ar-CH<sub>2</sub>SO<sub>2</sub>), and 2.1–2.9 (multiplet, 9 H, aromatic protons).

(34) J. von Braun, W. May, and R. Michaelis, *Ann.*, **490**, 189 (1931).

*Anal.* Calcd for C<sub>15</sub>H<sub>14</sub>Cl<sub>2</sub>O<sub>2</sub>S: C, 54.72; H, 4.29; Cl, 21.54. Found: C, 54.50; H, 4.33; Cl, 21.64.

**Rearrangement of 10.** A solution of 4.94 g (15.0 mmoles) of **10** in 45 ml of 2.0 *N* sodium hydroxide solution (90 mmoles) and 45 ml of dioxane was refluxed for 4 hr. Work-up of the reaction mixture afforded a neutral, ether-soluble fraction and an aqueous solution. Vpc analysis of the neutral residue indicated the presence of 19% phenyl *p*-tolylacetylene (**16**) and 4% of a *cis*- and *trans*-vinyl chloride mixture. A sample of **16** was collected by preparative vpc, mp 72–73° (from ethanol) (lit.<sup>35</sup> mp 78–79°). The infrared and nmr spectra were entirely consistent with the structural assignment.

The aqueous portion was concentrated to a volume of about 40 ml, acidified, and treated with *p*-toluidine. A brownish solid was obtained which weighed 4.10 g (72%), mp 160–175°. Recrystallization of this mixture of sulfonic acid salts from water gave an analytical sample as colorless needles, mp 169–172° (partial liquefaction) and 194–197° (clear melt);  $\nu_{\text{max}}^{\text{Nujol}}$  3.80 (NH<sub>3</sub><sup>+</sup>), 8.33, 8.60, and 9.46 (SO<sub>2</sub>).

*Anal.* Calcd for C<sub>22</sub>H<sub>23</sub>NO<sub>3</sub>S: C, 69.26; H, 6.08; N, 3.68. Found: C, 69.63; H, 6.22; N, 3.85.

**Rearrangement of 13.** A solution of 1.48 g of **13** in 13.5 ml of 2.0 *N* sodium hydroxide solution (27 mmoles) and 13.5 ml of dioxane was refluxed for 4 hr. There was isolated a 23% yield of **16**, a 6% yield of a vinyl chloride mixture, and a 68% yield of the vinyl-sulfonic acid mixture (**14** and **15**) as their *p*-toluidine salts, mp 160–175°, identical in all respects with the crude salt obtained from **10**.

(35) G. Driefahl and G. Plotner, *Chem. Ber.*, **91**, 1274 (1958); our sample was found by vpc to contain approximately 3% of vinyl chloride impurity.

## $\alpha$ -Halo Sulfones. VII. The Ramberg-Bäcklund Rearrangement of $\alpha,\alpha$ -Dichloromethyl Sulfones<sup>1-3</sup>

Leo A. Paquette,<sup>4</sup> Lawrence S. Wittenbrook, and Vinayak V. Kane

Contribution from the Department of Chemistry, The Ohio State University, Columbus, Ohio 43210. Received March 9, 1967

**Abstract:** Several  $\alpha,\alpha$ -dichloromethyl sulfones have been subjected to treatment with various bases in an attempt to elucidate the possible mechanistic pathways involved in the ensuing rearrangement. In particular, the selection of sulfones was designed to allow an examination of the possible generation and fate of monosubstituted thiirene dioxides and spirochloro episulfones, two intermediates anticipated from earlier results. The Ramberg-Bäcklund rearrangement of the dichloromethyl sulfones was found to give rise to acetylenes, vinyl chlorides, and  $\alpha,\beta$ -unsaturated sulfonic acids. The mode of formation of these products is discussed. 2-Chlorothiirane 1,1-dioxide, the parent of the chloro episulfone series, has been prepared and its decomposition studied.

In recent years, there has been considerable attention directed toward an elucidation of the mechanistic details involved in the transformation of  $\alpha$ -halo sulfones to olefins in the presence of base (the Ramberg-Bäcklund rearrangement).<sup>5</sup> A rate-determining 1,3 elimination

(1) We thank the National Institutes of Health and the Petroleum Research Fund, administered by the American Chemical Society, for grants used in support of this work.

(2) Presented in part at the 151st National Meeting of the American Chemical Society, Pittsburgh, Pa., March 1966.

(3) Paper VI: L. A. Paquette and L. S. Wittenbrook, *J. Am. Chem. Soc.*, **89**, 4483 (1967).

(4) Fellow of the Alfred P. Sloan Foundation.

(5) (a) L. Ramberg and B. Bäcklund, *Arkiv Kemi, Mineral. Geol.*, **13A**, No. 27 (1940); *Chem. Abstr.*, **34**, 4725 (1940); (b) F. G. Bordwell and G. D. Cooper, *J. Am. Chem. Soc.*, **73**, 5187 (1951); (c) N. P. Neureiter and F. G. Bordwell, *ibid.*, **85**, 1209 (1963); (d) L. A. Paquette, *ibid.*, **86**, 4053 (1964); (e) L. A. Paquette, *ibid.*, **86**, 4383 (1964); (f) N. P. Neureiter, *J. Org. Chem.*, **30**, 1313 (1965); (g) N. P. Neureiter, *J. Am. Chem. Soc.*, **88**, 558 (1966).

of hydrogen halide to give rise to episulfones, followed by their decomposition with expulsion of sulfur dioxide, is now the accepted mechanism. The extension of this reaction to  $\alpha,\alpha$ -dichloro sulfones (**1**) was previously demonstrated to proceed in an analogous fashion.<sup>3,6</sup> Products have been shown to result from the formation and subsequent decomposition of chloro episulfones (**2**) and thiirene dioxides (**3**). However, the earlier studies have concentrated exclusively on dihalo sulfones which ultimately could lead only to disubstituted thiirene dioxides (**3**, R = alkyl or aryl).

We wish now to report the results of studies on the base-promoted rearrangement of dichloromethyl sul-

(6) (a) L. A. Paquette, *ibid.*, **86**, 4089 (1964); (b) L. A. Carpino and L. V. McAdams, III, *ibid.*, **87**, 5804 (1965); (c) L. A. Paquette and L. S. Wittenbrook, *Chem. Commun.*, 471 (1966).